



# PSS 5000

## Installation Guide

For systems with CPB539



*Standard cabinet (conduits)*

*Standard cabinet (grommets)*

*Compact cabinet*

Date February 20, 2023  
Document number PSS5000/INGU/805799/10

Doms ApS Formervangen 28 Tel. +45 4329 9490 info@doms.dk  
DK-2600 Glostrup www.doms.com

## About This Documentation

### **Purpose**

This documentation describes the preparations and installation procedures for the PSS 5000 Forecourt Controller on an operational site. When you are finished using this guide, the controller will be mounted correctly, connected to all the necessary devices and relevant equipment, and ready to be used.

### **Audience**

The content of this documentation is designed for personnel, such as maintenance staff or service technicians, who have received the necessary training and are required to install the controller hardware on a filling station.

## Software

### **Software License**

This product contains software that is covered by the GNU General Public License. A list of the software packages present and copies of the relevant licenses can be found in **4.1. Software Versions** using the FCC Web Application on the embedded web server.

# Contents

	About This Documentation .....	2
	Software .....	2
<b>1</b>	<b>Safety Information .....</b>	<b>4</b>
1.1	Environmental Conditions .....	4
<b>2</b>	<b>Installing the PSS 5000 Forecourt Controller .....</b>	<b>5</b>
2.1	Mount the Cabinet .....	6
2.2	Power Up the PSS 5000 .....	8
2.3	Set the IP Address .....	9
2.4	List the Protocol to Port Assignments .....	15
2.5	Cable the Forecourt Devices .....	17
2.6	Validate Device Connectivity .....	20
<b>3</b>	<b>Maintenance .....</b>	<b>22</b>
3.1	Changing Fuses .....	22
3.2	Changing Hardware Interface Modules (HIMs) .....	23
<b>4</b>	<b>Technical Data .....</b>	<b>25</b>
<b>5</b>	<b>Revision Information .....</b>	<b>29</b>

# 1 Safety Information

## Warnings!



**Do not install this equipment in a hazardous area.**

**Do not install this equipment unless you have the proper training.**

**Note:**

The CPB has its own UPS. Consequently, the board may be energized even if it is disconnected from the Mains power source.

## 1.1 Environmental Conditions

### Fuels and Vapours

Because this equipment is connected to equipment installed in an environment with fuel and fuel vapours, there is a risk of fire and explosion. Ensure that safety equipment is installed and adequate precautions are taken to minimize the risk of injury or death.

### Emergency Power Cut-off

Make sure that an emergency power cut-off is installed. This must be accessible and removes the AC power from all the fuelling devices on site.

### Electrical Circuits

Remove the power to the forecourt controller before inserting, connecting or removing any of the electrical circuits in this equipment.

The common Ground of the communication circuits (HIMs) must be connected to the protective earthing, classifying the HIMs circuits as Network environment 0 as per TR62102, when connected to outdoor protectively earthed SELV. This allows the HIMs circuits to be connected to the outdoor protectively earthed SELV without separation.

### High Voltage

This equipment uses either 120 VAC or 230 VAC. Make sure all safety procedures are followed. Failure to do this can result in death.

## 2 Installing the PSS 5000 Forecourt Controller

### Prerequisites

The cabinet must be mounted close to a suitable Mains power supply, an Ethernet connection, and the ends of the communication cables for both the forecourt and POS devices.

### Installation Process

This process lists the separate stages involved in installing the PSS 5000.

**Note:** It is assumed that the correct Hardware Interface Modules (HIMs) are present and the protocols are assigned to the relevant ports.

Stage	Description
1	<a href="#">Mount the Cabinet</a>
2	<a href="#">Power Up the PSS 5000</a>
3	<a href="#">Set the IP Address</a>
4	<a href="#">List the Protocol to Port Assignments</a>
5	<a href="#">Cable the Forecourt Devices</a>
6	<a href="#">Validate Device Connectivity</a>

### What's next!

On completion of the installation process, you are ready to start configuring the system. The configuration process is described in the Online Help of the FCC Web Application.

## 2.1 Mount the Cabinet

### Mounting options

Use the correct procedure for the type of cabinet you want to mount:

- ‘To mount the PSS 5000 Standard cabinet’ on page 6
- ‘To mount the PSS 5000 Compact cabinet’ on page 7

### To mount the PSS 5000 Standard cabinet

This procedure describes how to mount the PSS 5000 standard cabinet.

**Note:** Only install the PSS 5000 in the prescribed environment.

1. Find a spot where there is enough space for both the cabinet and the cable connections located to the right and below the cabinet.

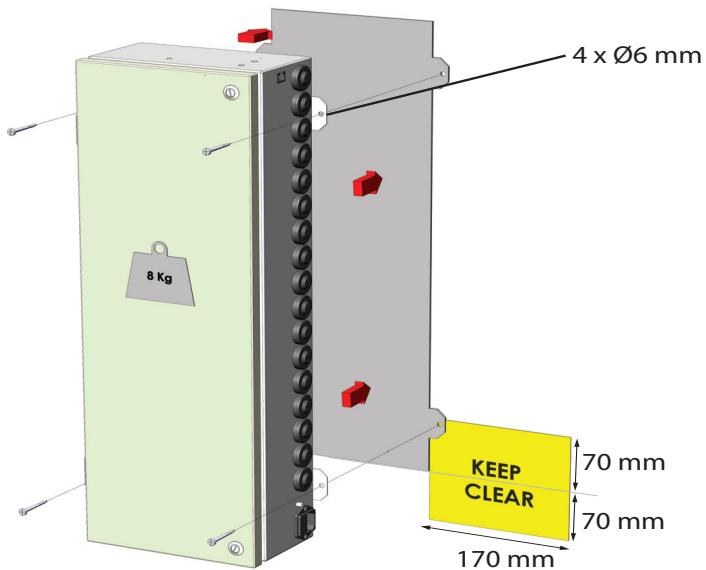

*Illustrated with a Standard cabinet with grommets*

2. Secure the PSS 5000 to the wall using the mounting lugs on the cabinet. The mounting lugs are located on the sides of the Standard cabinets.

**Note:** Use screws or bolts that are capable of supporting the weight of the cabinet and its contents.

3. Loosen the screws securing the door so that you can open the door and access the inside of the cabinet.

You are now ready to continue to the next step in the process.

### To mount the PSS 5000 Compact cabinet

This procedure describes how to mount the PSS 5000 compact cabinet.

**Note:** Only install the PSS 5000 in the prescribed environment.

1. Find a spot where there is enough space for both the cabinet and the cable connections located to the right and below the cabinet.

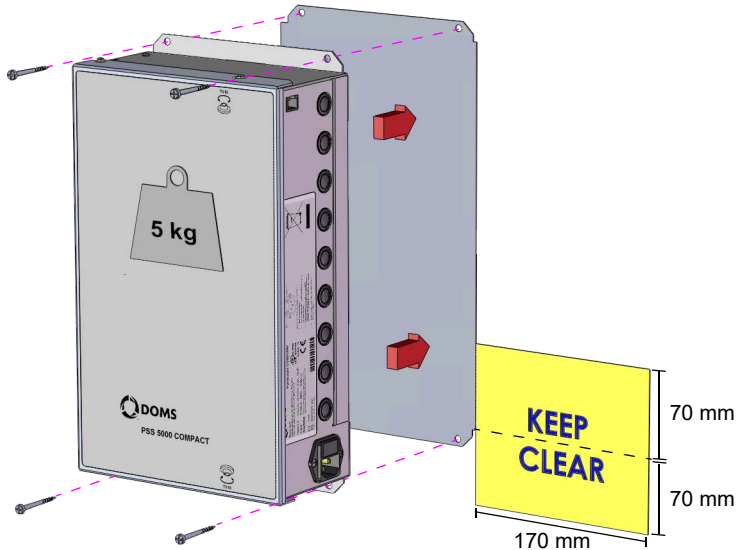

2. Secure the PSS 5000 to the wall using the mounting lugs on the cabinet. The mounting lugs are located above and below the Compact cabinets.

**Note:** Use screws or bolts that are capable of supporting the weight of the cabinet and its contents.

3. Loosen the screws securing the door so that you can open the door and access the inside of the cabinet.

You are now ready to continue to the next step in the process.

## 2.2 Power Up the PSS 5000

### To power up the PSS 5000

This procedure describes how to connect the power cable and LAN Ethernet connection to the PSS 5000.

1. Locate the power inlet socket on the right-hand side to the cabinet and insert the power cable provided.

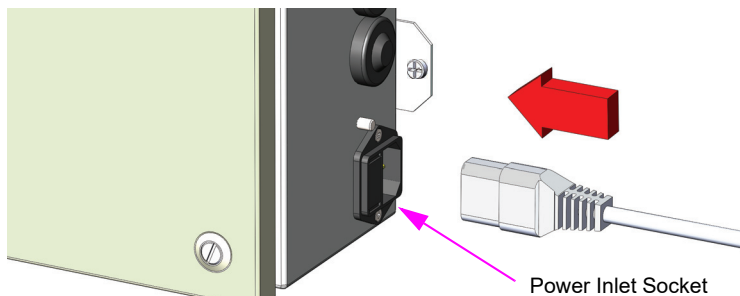

*Illustrated with a Standard cabinet with grommets*

2. Connect the power cable to the Mains supply.

**Note:** The Mains connection must comply with the local electrical codes and standards and match the voltage and power rating of this equipment.



3. Locate the external Ethernet port on the right-hand side of the cabinet and connect an Ethernet cable to the LAN.

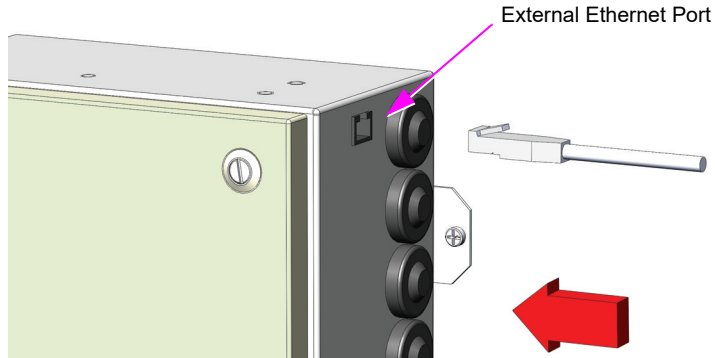

*Illustrated with a Standard cabinet with grommets*

You are now ready to continue to the next step in the process.

## 2.3 Set the IP Address

### IP Address Assignments

Port 41 can be assigned the following types of IP addresses:

- Dynamic – assigned by a DHCP server
- Static – assigned manually via the service menus

**Note:** We recommend using a Static IP address as a dynamic IP address may make it difficult to access the PSS 5000 remotely.

**Note:** The IP addresses for Port 41 and Port 42 must belong to separate subnets. For example:

Port 41 – **192.168.0.x / 255.255.255.0**

Port 42 – **192.168.42.2 / 255.255.255.0.**

### **Methods of Setting the IP address of the LAN Port**

The IP address for Port 41 on the CPB539 can be set in one of two ways:

- [To assign an IP address to Port 41 \(via a browser\)](#)
- [To assign an IP address to Port 41 \(via Local Service Panel\)](#)

To ensure that the TCP/IP information provided for Port 41 is correct, you should obtain the necessary details from your System Administrator before you start.

### **See Also**

- [‘IP Address Assignments’ on page 9](#)

### **To assign an IP address to Port 41 (via a browser)**

This procedure describes how to assign an IP address to Port 41 using a browser and the FCC Web Application.

1. Use standard Windows procedures to set the IP address of the Ethernet port on your Service PC to **192.168.42.10**.

This makes it compatible with the fixed IP address assigned to Port 42.

2. Locate Port 42 on the CPB and using a suitable Ethernet cable connect it to your Service PC.

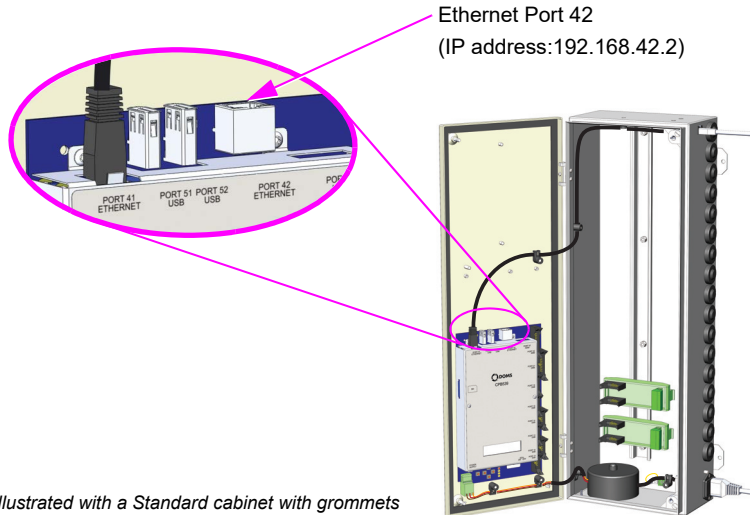

*Illustrated with a Standard cabinet with grommets*

3. Open a standard browser on your Service PC and in the URL field type in the IP address for Port 42: **192.168.42.2**.

**Note:** If a 3rd party web application is installed, select the FCC Web App option.

The **Sign In** window for the FCC Web Application appears.

4. Sign in using the default authentication details for the FCC Web Application.

**Note:** The default user name and password are provided in the FCC Web Application Software Release Document (SRD).

A new **Change Password** window appears.

5. Type in a new password, confirm it and click  .

The **Forecourt Devices** window appears.

6. Select **5. Setup** → **5.6. Communication** → **5.6.1. TCP/IP**.

The **TCP/IP** window appears. This shows the current details for both Port 41 and Port 42.

7. Do one of the following:

- **(Recommended)** To assign a static IP address, go to step 8.
- To assign a dynamic IP address, select **Enable DHCP Client** and go to step 9.

8. Select Port 41 and type in the required values for:

- **IP Address**
- **Subnet Mask**
- **Default Gateway**

**Note:** Set the IP address so that Port 41 and Port 42 belong to separate subnets.

To ensure that the information provided here is correct, you should obtain the necessary details from your System Administrator.

9. Click  to apply the changes.

After the IP address has been changed, the FCC Web Application is also accessible from the LAN. You are now ready to proceed to the next step in the process.

### See Also

- [‘IP Address Assignments’ on page 9](#)

### To assign an IP address to Port 41 (via Local Service Panel)

This procedure describes how to use the Local Service Panel (LSP) on the CPB539 to set an IP address for Port 41. This is used to connect the PSS 5000 to the LAN.

**Note:** This procedure describes how to assign a static IP address. If you need to use a dynamic address, select "YES" when you see "USE DHCP?".

1. Obtain a valid IP address for the connected LAN from the System Administrator.
2. Locate the local service panel and navigation buttons.

*Illustrated with a Standard cabinet with grommets*

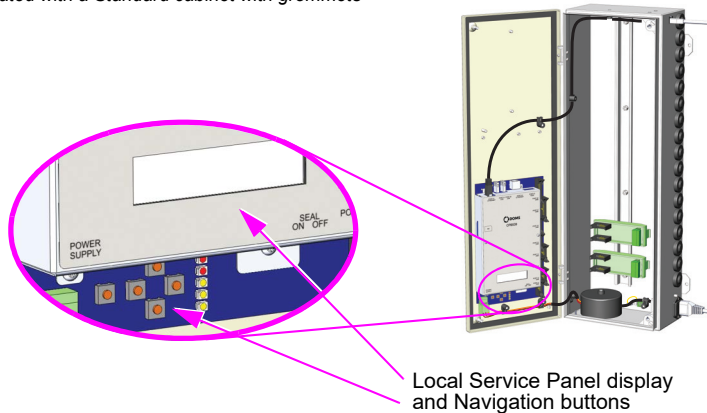

- Use the navigation buttons as shown below to set the IP address and gateway for Port 41.

**Note:** Set the IP address so that Port 41 and Port 42 belong to separate subnets.

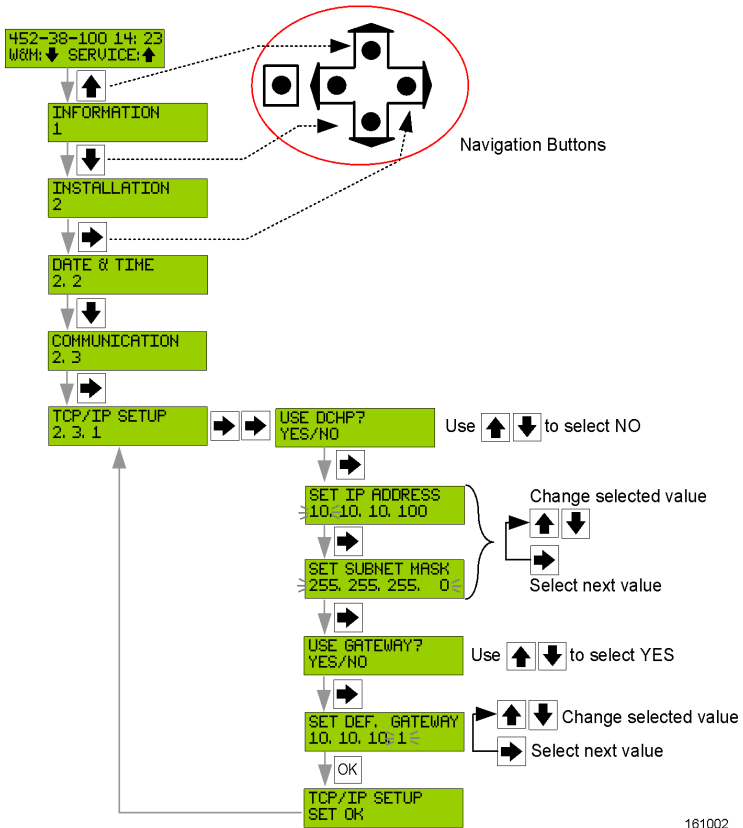

The PSS 5000 can be connected to the LAN and you are ready to proceed to the next step in the process.

#### See Also

- [‘IP Address Assignments’ on page 9](#)

## 2.4 List the Protocol to Port Assignments

### To view the current protocol to port assignments

This procedure describes how to use the FCC Web Application to view which protocols are assigned to the individual serial ports on the CPB.

**Note:** If you have a PC connected to the LAN already, go to step 2.

1. Use an Ethernet cable to connect a PC to the LAN or to Port 42 on the CPB.

**Note:** If you are connecting to Port 42, you must set up the Ethernet port on the PC to match the IP address range used by Port 42.

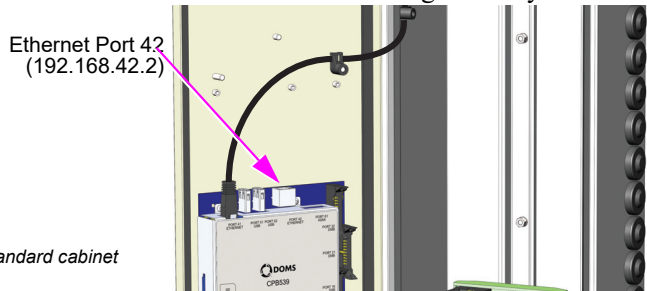

*Illustrated with a Standard cabinet with grommets*

The default IP address for Port 42 is **192.168.42.2**.

2. Open a web browser on the PC and, in the URL field, do one of the following:
  - If connected via the LAN, type in the IP address of Port 41.
  - If connected via Port 42, type in 192.168.42.2

The **Sign In** window appears.

3. Sign in to the FCC Web Application.
  - If you used the FCC Web Application to set the IP address, sign in with the user defined password.
  - If the FCC Web Application has not been accessed previously, use the default authentication details and then change the password.

**Note:** The default user name and password are provided in the FCC Web Application Software Release Document (SRD).

**4. Select 5. Setup → 5.3. Protocol to Port Assignment.**

A list of all the ports and the corresponding protocol to port assignments appears.

Protocol to Port Assignment

Port	Protocol
11	Doma PSS Communication (High Speed) IFSF Driver IFSF Pump IFSF Pricepole <span style="float: right;">✎ ✕</span>
12	+
13	+
14	+
15	+
16	+
21	MKS ER 3/2 Pump <span style="float: right;">✎ ✕</span>
22	V.11 Scheidt&Bachmann T10/T20 Pump & Price Pole <span style="float: right;">✎ ✕</span>
41	Doma Presentation Layer Doma POS (TCP/IP) <span style="float: right;">+</span>
99	+

**5. Keep this page open and use the protocol to port assignment information to assist you in connecting the forecourt devices to the correct Hardware Interface Modules (HIMs).**



## 2.5 Cable the Forecourt Devices

### To connect the cables for the forecourt devices

**Caution:** The communication wiring must be isolated from high voltage circuits and must not use the same grommet or conduit as AC conductors.

**Note:** It is assumed that the relevant HIMs are installed already. This procedure describes how to insert the communication cables from the forecourt devices and prepare them for connection to the Hardware Interface Modules (HIMs).

1. Prepare the communication cables by removing the insulation as illustrated below.

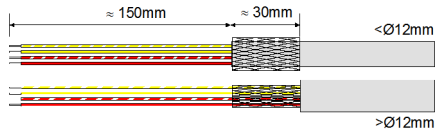

2. Do one of the following:

- **For cabinets with grommets:**  
Insert any cables with  $< \varnothing 12\text{ mm}$  through the grommet. For cables  $> \varnothing 12\text{ mm}$ , cut the grommet as shown before inserting them.
- **For cabinets with conduits:**  
Remove the seals from the wire inlet holes used in the installation, and install the conduits and conduit connectors (not included) in these holes.

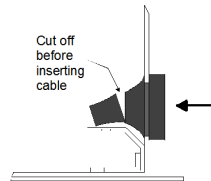

3. Refer to the **Protocol to Port Assignment** web service page and insert each communication cable through the grommet/conduit opposite the relevant HIM.

**Caution:** Do not insert communication cables and AC voltage cables through the same grommet/conduit.

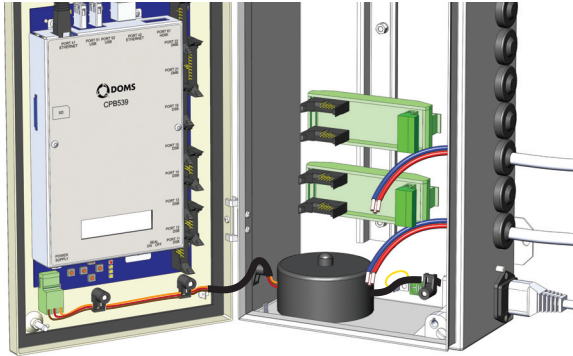

*Illustrated with a Standard cabinet with grommets*

4. Secure each cable to the cabinet (see illustrations below) and connect the cable to the HIM.
  - **For cabinets with grommets:**  
Use the cable clamp provided as shown below.

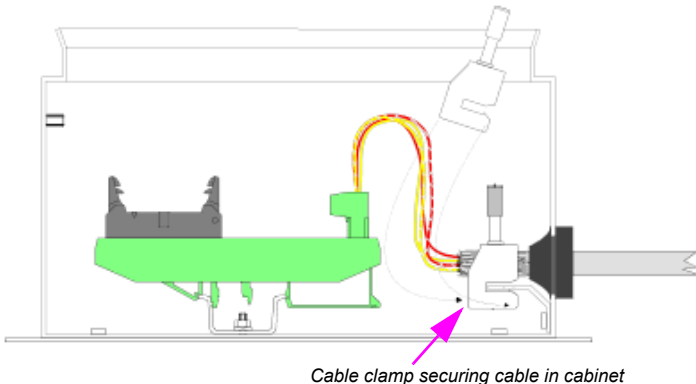

- **For cabinets with conduits:**  
Use cable ties to secure the wires to the wire strain relief bar as shown below.

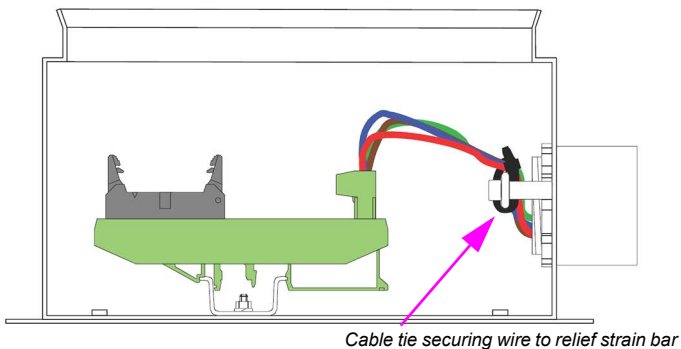

5. Make sure that the electrical connections meet the standards required by the relevant national regulations. And to minimize the risk of Ground Potential Differences, whenever possible, ensure that all the devices on the site have a Common Ground Reference, or alternatively, a Protective Earth can be implemented.

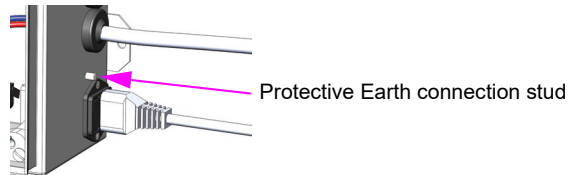

**Note:** For more information about general installation recommendations, refer to the DOMS Forecourt Controller System, Installation Recommendations (806070/--).

**Note:** For more information about the cable connections to the individual HIMs, refer to the relevant installation drawings for the modules.

You are now ready to validate that all the forecourt devices are connected correctly and communicating with the PSS 5000.

## 2.6 Validate Device Connectivity

**To validate connectivity between the PSS 5000 and the forecourt devices**

This procedure describes how to validate that the forecourt devices are communicating correctly with the PSS 5000.

1. Using a web browser, open the FCC Web Application.

## 2. Select **7. Diagnostics** → **7.1. Online List**.

The **Online List** page appears.

**Main Menu**

- 1. Live Status
- 2. Operation
- 3. Reports
- 4. Information
- 5. Setup
- 6. Configuration
- 7. Diagnostics
  - 7.1. Online List
  - 7.2. Tests
    - 7.2.1. Price Poles
    - 7.2.2. Terminal Test
  - 7.3. Logs
    - 7.3.1. System
      - 7.3.1.1. Platform
      - 7.3.1.2. Access
      - 7.3.1.3. Reset
    - 7.3.2. PSS
      - 7.3.2.1. Upload
      - 7.3.2.2. Reset
      - 7.3.2.3. Device Error
      - 7.3.2.4. Memory Module
  - 7.4. Communication
    - 7.4.1. Port Statistics
  - 7.5. Pico
- 8. Authorities

### Online List

Port	Protocol	Device Address	Configured ID
11	Veeder/Root Tank Gauge 2400 Veeder/Root ADR Reconciliation 2400	Tank Gauge 1	
		Tank Gauge 2	
		Tank Gauge 3	
		Tank Gauge 4	
		Tank Gauge 5	
12		Tank Gauge 6	
13	Gibarco Pump (4800 baud) (Incl. Australia)	Fuelling Point 1	
		Fuelling Point 2	
		Fuelling Point 3	
		Fuelling Point 4	
		Fuelling Point 5	
		Fuelling Point 6	
		Fuelling Point 7	
		Fuelling Point 8	
14			

## 3. Make sure that each forecourt device is listed in the **Device Address** column.

If this is not the case, repeat the steps in this section:

- Check that the devices are connected correctly
- All the devices are powered up
- The Protocol to Port Assignments match the device connections and HIM connections

The installation is now complete and you are ready to configure the PSS application. The configuration is achieved using the FCC Web Application.

## 3 Maintenance

### Maintenance overview

This section is divided in to the following sub-topics:

- [‘3.1 Changing Fuses’ on page 22](#)
- [‘3.2 Changing Hardware Interface Modules \(HIMs\)’ on page 23](#)

### 3.1 Changing Fuses

#### To replace the fuse

This procedure describes how to remove defective Mains fuses from the PSS 5000 Forecourt Controller and replace them with new ones.

1. Turn off the power by removing the plug from the power inlet socket.
2. Locate the fuse drawer, which is located at the power inlet socket.
3. Using 2 small flat-blade screwdrivers (max. 2.5 mm), insert the tip of each screwdriver into the small hole next to the fuse drawer as illustrated below.

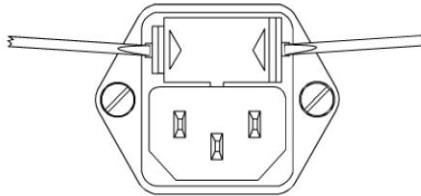

4. Press the handle of the screw drivers carefully towards the box so that the fuse drawer is pushed outwards.
5. Remove the defective fuse from the fuse drawer.

The fuse drawer is divided into 2 sections. This provides space for a spare fuse; so use the spare one if available.

6. Make sure that the new fuse has the correct rating and insert it in the fuse drawer.

**Note:** The correct ratings for the equipment are indicated on the label next to the power inlet socket.

7. Close the drawer.

**Note:** Before you reconnect the Mains power, make sure that the reason for the blown fuse has been eliminated.

## 3.2 Changing Hardware Interface Modules (HIMs)

### To remove a HIM

This procedure describes how to remove a HIM from the PSS 5000 cabinet.

1. Turn off the power by removing the plug from the power inlet socket.
2. Open the front cover by releasing the securing screws (and the lock if present).
3. Disconnect the cables to the HIM that you want to remove.
4. Insert a flat-blade screwdriver in the groove indicated in drawing (i) below.

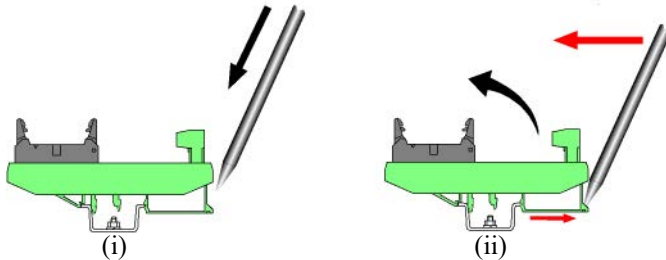

5. Gently prise the securing clip open by pressing the screwdriver in the direction indicated by the red arrow in drawing (ii) illustrated above.
6. When the securing clip is free, use your other hand to tip the HIM clear of the DIN rail and then lift it out of the cabinet.

### To insert a HIM

This procedure describes how to insert a HIM into the PSS 5000 cabinet.

1. Turn off the power by removing the plug from the power inlet socket.
2. Open the front cover by releasing the securing screws (and the lock if present).
3. Angle the module so that the side closest to the door is inserted on to the DIN rail.

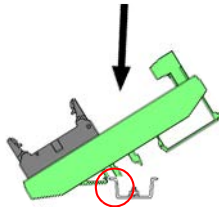

4. Slide the module along the rail until it is in position, typically opposite the port to which it will be connected.
5. Press the other side of the module (closest to the cable inlets) until it clicks on to the DIN rail and is secure.

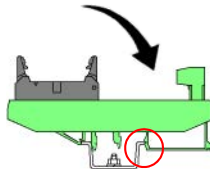

6. Connect the HIM to the CPB using a flat serial cable.

You are now ready to connect the cable from the forecourt device.

**Note:** If the cable to the forecourt device is a new connection, remember to secure this cable connection to the cabinet with a cable clamp.

**Note:** Remember to select the correct Protocol to Port Assignment.

### See Also

- [‘2.4 List the Protocol to Port Assignments’ on page 15](#)



## 4 Technical Data

### General information

Only equipment approved by Doms ApS is permitted to be installed in the PSS 5000 Forecourt Controller.

The cables connecting the Hardware Interface Modules (HIMs) to the forecourt devices should be twisted pair with a braided shield and with a minimum 80% cover.

It is important that both ends of the cable shield are connected correctly.

### Physical data

The physical parameters of the PSS 5000 have the following values:

Physical Parameter	Standard / North America	Compact
Dimensions (H x W x D)	600 x 200 x 124 mm (23.5 x 7.9 x 4.9 inches)	363 x 200 x 100 mm (13.3 x 7.9 x 3.9 inches)
Weight (approx. incl. HIMs)	8 kg (17.6 lbs)	5 kg (11 lbs)
Ingress protection	IP30	IP30

### Environmental data

The environmental parameters of the PSS 5000 have the following values:

Environmental	
Operating temperature range	-30°C to +55°C
Storage temperature range	-30°C to +55°C
Ambient humidity	Max. 90% RH, non-condensing
Electromagnetic Environment Class (E1) (OIML D11 2004: residential, commercial and light industrial building)	

### Environmental

Mechanical Environment Class (M1)  
(MID, 2004/22/EC D11 2004), (locations with vibration and shocks of low significance)

### Electrical data

The electrical parameters of the PSS 5000 have the following values:

#### Electrical

Recommendation: supplied power uses the same Mains phase as:

- POS (Point Of Sale)
- BOS (Back Office System)
- Forecourt devices (electronics for dispensers, terminals, tank gauges, etc.)

The Mains cable must be installed according to the local regulations. The Mains power to the PSS 5000 is switched off by removing the Mains cable.

#### 230 V version

Mains power voltage (max.)	230 VAC +10% = 253 VAC
Mains power voltage (min.)	230 VAC – 15% = 195 VAC
Mains power frequency	50 Hz/60 Hz

*Standard power supply:*

Max. power consumption	43 VA
Fuse, 5 x 20mm, slow blow	T400mA

*Dual Trafo power supply:*

Max. power consumption	55 VA
Fuse, 5 x 20mm, slow blow	T630mA

#### 120 V version

Mains power voltage (max.)	120 VAC +10% = 132 VAC
Mains power voltage (min.)	120 VAC – 15% = 102 VAC
Mains power frequency	50 Hz/60 Hz
Max. power consumption	43 VA
Fuse, 5 x 20mm (0.2" x 0.8"), slow blow	T1A

### Approvals data

The approvals for the PSS 5000 are:

Approvals
<ul style="list-style-type: none"> <li>• UL, 62368-1 2nd Ed. / CSA-C22.2 No. 62368-1 2nd Ed.</li> <li>• CB, IEC 62368-1</li> <li>• Customs union EAEU EAC C-DK.HA10.B.00016 and EAC C-DK.HA10.B.00596</li> <li>• MID Parts Certificate, SC0257-15</li> <li>• Australia NMI certificate S748</li> <li>• Mexico NOM-019-SCFI-1998 registration</li> <li>• Mexico NOM-185-SCFI-2012 certificate DGN.312.01.2019.858</li> </ul>

### System States

The LED states in the table below indicate the status of the system.

LEDs			Status
POWER	SYSTEM	PSS	
On	On	Off	Only Boot loader running
Flash (1 Hz)	On	–	Boot loader running but low power (UPS charge in progress)
On	On	On	Linux kernel is starting
–	Flash (heart beat)	–	Linux kernel running
Off	Flash (heart beat)	–	Linux shutdown in progress
Flash (heart beat)	Flash (heart beat)	–	Linux running but NO Mains power
On	Flash (heart beat)	Flashing (0.5 Hz)	Normal Operation: Power ON, Linux kernel running and PSS Suite operational
"–": indicates that this LED is not applicable			

**PSS Suite States**

The LED states provided in the table below indicate the status of the PSS Suite software.

PSS LED	Status
Off	PSS Application is not running
On	PSS Suite error state
Flashing (0.5 Hz)	PSS Suite operational

## 5 Revision Information

### Revision History

This documentation has changed as follows:

Rev.	Date	Description of Changes
00	Jun. 13, 2016	First release.
01	Nov. 04, 2016	Updated illustrations containing a CPB539.
02	Dec. 15, 2016	Updated default IP address for Port 41.
03	Jan. 17, 2017	Updated section 2 – Installation with a note: The IP addresses of Port 41 & Port 42 must belong to separate subnets.
04	Jan. 27, 2017	Added LED status information to Technical Data section.
05	May 8, 2017	Updated the default IP address for Port 42. Minor text corrections.
06	Sept. 20, 2017	Updated the safety information for electrical circuits.
07	Jun 21, 2018	Updated the sign in procedure: <ul style="list-style-type: none"><li>• With a default sign in, it is necessary to create a new password.</li><li>• When a 3rd party web application is installed it is necessary to select FCC Web App to continue.</li></ul>
08	Jul. 2, 2020	The following changes have been made: <ul style="list-style-type: none"><li>• In Electrical Circuits section changed TR62101 to TR62102</li><li>• Updated the cabling information for shielded cables</li><li>• Included the PSS 5000 Compact</li></ul>
09	Mar. 24, 2021	Updated list of Approvals, including EN60950-1 to EN62368-1
10	Feb. 20, 2023	Updated with Standard cabinet with grommets option (North America cabinet)